

ROXSAT

☆ SPECIFICATION

Protocol	: DiSEqC 1.2
Compatible Receiver	: DiSEqC 1.2 Receiver
Antenna Size	: 120 cm Max.
Speed	: 1.9°/ sec (at 13V); 2.5°/ sec (at 18V)
Azimuth Angle	: 75°East ~ 75°West (150°Max.) Adjustable
Elevation Angle	: 10~75°
Tube for Antenna	: Ø 42 x 170L mm
Diameter of Stand-mast	: Ø 35~65 mm
Input Voltage	: 13 / 18Vdc
Output Voltage	: 13 / 18Vdc (according to input)
Power Consumption	: 50 mA (Standby) / 200mA (Normal) / 350mA (Max.)
Satellite Positions	: 60 positions
Goto 0 Position Function	: Yes (Go to 0°)
Recalculation Function	: Yes
Goto X Function	: Yes
Manual Button	: Yes (East /West)
Indicating LED	: Yes (2 Colors)
	: 1. Adjustable Hardware Limits
Limit Protection	2. Programmable Software Limit
	3. Current Limit
Positioning Sensor	: High Resolution Hall Effect Sensor
Weight	: 3.1 Kg (Net) / 3.5 Kg (Gross)
Dimension	: 345 x 168 x 110 mm ³ (Gross)

DiSEqC™ is a trademark of EUTELSAT

☆ BUILT-IN SAT. TABLE

No.	Satellite	Position
1	Hot Bird	13°E
2	Astra	19.2°E
3	Eutelsat W2	16°E
4	Eutelsat W1	10°E
5	Eutelsat W3	7°E
6	Sirius 2/3	5°E
7	Thor 2/3	0.8°W
8	Intelsat 707	1°W
9	Telecom 2C	5°W
10	Telecom 2D	8°W
11	Intelsat 705	18°W
12	NSS 803	21.5°W
13	Intelsat 605	27.5°W

No.	Satellite	Position
14	Hispasat	30°W
15	Telstar 11	37.5°W
16	Kopernicus	23.5°E
17	Arabsat 2A / 3A	26°E
18	Astra 2	28.2°E
19	EuroBird	28.5°E
20	Arabsat 2B	30.5°E
21	Turksat 1B	31.3°E
22	Turksat 1C	42°E
23	Intelsat 601	34.5°W
24	Pas 3R	43°W
25	Amos	4°W
26	Nilesat	7°W

62BSG210W4

DiSEqC 1.2 Motorized H-H Motor

SG-2100

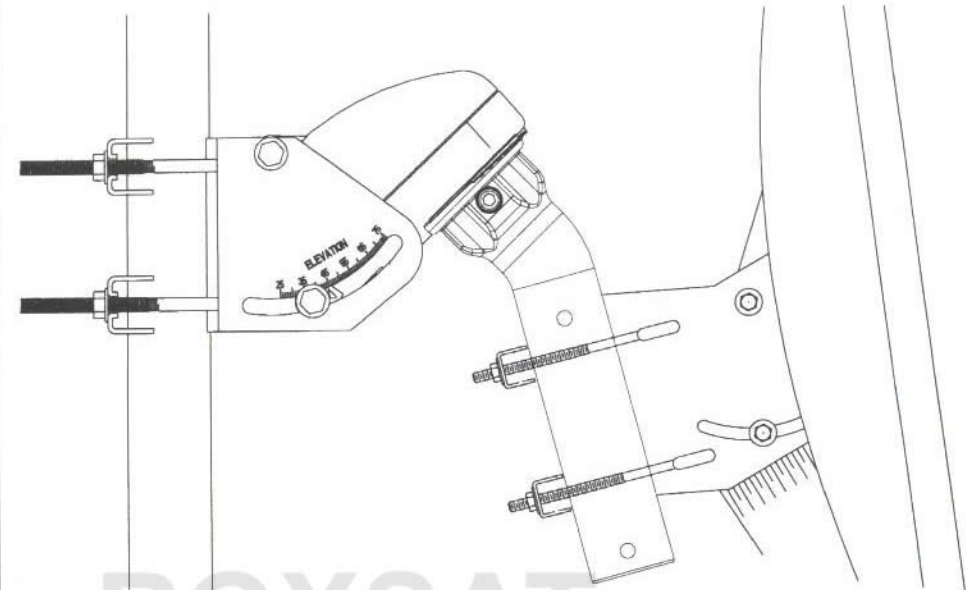

ROXSAT

- ☆ Compatible with DiSEqC 1.2 Receivers
- ☆ Adjustable Hardware Limit Switches
- ☆ Indicating LED for Easy Trouble Shooting
- ☆ Manual Button for Easy Installation
- ☆ Compact, Powerful and Quiet
- ☆ For Dish up to 1.2 M
- ☆ Goto X Function



★ TROUBLESHOOTING

Symptoms	Check points
The Manual Button doesn't work	<ol style="list-style-type: none"> 1. Make sure the power of receiver is on and the indication LED on the bottom of the motor lights on. 2. Check every devices between receiver and motor.
The Manual Button can only drive the motor toward West	For East movement: Press the manual button twice within 1 second or a shorter time.
The Motor doesn't work	<ol style="list-style-type: none"> 1. Make sure all cables and power are well connected. The LED on the bottom lights on. 2. Make sure the motor is not blocked by the software limits. Try to use the manual button, which is only limited by hardware limits. 3. Check if the receiver supports DiSEqC 1.2 and if the DiSEqC 1.2 system has been enabled.
The Motor stops at a certain position and can't go further.	<ol style="list-style-type: none"> 1. Disable the software limits and drive the motor again. 2. Check if it's stopped by the hardware limit sliders. 3. Make sure the Motor or antenna is not interfered with any other item.
The Motor runs discontinuously	<ol style="list-style-type: none"> 1. Make sure the antenna is not too heavy or too large. The maximum size is 1.2 m. 2. Check if the cable quality is good enough. Try to use a better RG-6/U cable. 3. Check if the output power of the receiver is less than 350mA.
The Motor runs sometimes fast and sometimes slowly.	The speed of the Motor is according to the output voltage (13/18V) of the receiver. Vertical=13V=slow Horizontal=18V=fast
All satellite positions are not correct.	<ol style="list-style-type: none"> 1. Goto One satellite position via receiver. Wait for about 30 seconds until the motor stops. 2. Drive the antenna East or West until the reception of this satellite is clear. 3. Use "Re-calculate" Function to correct position via receiver. Or Use Goto 0 position Function to go to 0 degree as a reference point.
Only one or two satellite positions are not correct, the rest are OK.	<ol style="list-style-type: none"> 1. It's probably due to error operation while using DiSEqC 1.2 commands. Please just correct this position by re-store satellite position. 2. If this problem happens again and again, try to upgrade the receiver software to check if this problem is improved.
The Motor runs for only 1 seconds then stops. The LED shows orange.	This could be caused by a loosen magnet inside or hall sensor broken. Please contact your vendor for repair.
The Motor doesn't make any movement, but clicks from inside of the motor can be heard	<ol style="list-style-type: none"> 1. Check if the dish is too heavy. The maximum size of the antenna is 1.2 m. 2. The DC motor inside is broken. Please contact your vendor for repair.

If you need more technical support, please contact us by e-mail: moteck@seed.net.tw.

★ ELEVATION AND DECLINATION ANGLE TABLE

Your Site Latitude	Elevation Angle	Declination Angle
0	90	0.000
1	89	0.178
2	88	0.355
3	87	0.533
4	86	0.710
5	85	0.887
6	84	1.063
7	83	1.239
8	82	1.415
9	81	1.589
10	80	1.763
11	79	1.936
12	78	2.108
13	77	2.279
14	76	2.449
15	75	2.618
16	74	2.786
17	73	2.952
18	72	3.117
19	71	3.280
20	70	3.442
21	69	3.603
22	68	3.761
23	67	3.918
24	66	4.073
25	65	4.226
26	64	4.377
27	63	4.526
28	62	4.674
29	61	4.819
30	60	4.961
31	59	5.102
32	58	5.241
33	57	5.377

Your Site Latitude	Elevation Angle	Declination Angle
34	56	5.510
35	55	5.641
36	54	5.770
37	53	5.897
38	52	5.966
39	51	6.142
40	50	6.260
41	49	6.376
42	48	6.489
43	47	6.600
44	46	6.708
45	45	6.813
46	44	6.799
47	43	7.015
48	42	7.112
49	41	7.205
50	40	7.296
51	39	7.385
52	38	7.470
53	37	7.552
54	36	7.632
56	34	7.782
58	32	7.792
60	30	8.047
62	28	8.162
64	26	8.265
66	24	8.357
68	22	8.437
70	20	8.505
72	18	8.562
74	16	8.608
76	14	8.643
78	12	8.666
80	10	8.678

II. Quick Installation (A receiver with Goto X Function is necessary):

1. Set Elevation Angle of the motor:

According to the Latitude of your location, set the elevation angle of the motor. There is also a Latitude scale on the other side of the motor.

2. Mount the Dish:

Mount the Dish onto the motor. The centerline on the tube of the motor can help to mount the Dish on the center.

Find the **Declination** Angle by the attached ANGLE TABLE.

Set the Declination Angle by the scale on the antenna dish. The reading on the Dish scale should be:

30° - DECLINATION ANGLE Please refer to the drawing on Page 2.

3. Drive the motor to the position for a favorite satellite via the receiver:

Input the longitude and latitude of your location and choose a satellite with better signal. The receiver can calculate and drive the motor to right angle automatically.

4. Aim the Satellite:

Move the whole unit around the pole to find the strongest signal from the wanted satellite. Tighten everything and the installation is finished. It will take about only 10 minutes.

☆ CABLE CONNECTION

- Connect the Motor via the coaxial cable (RG-6/U is recommended) as the following diagram.

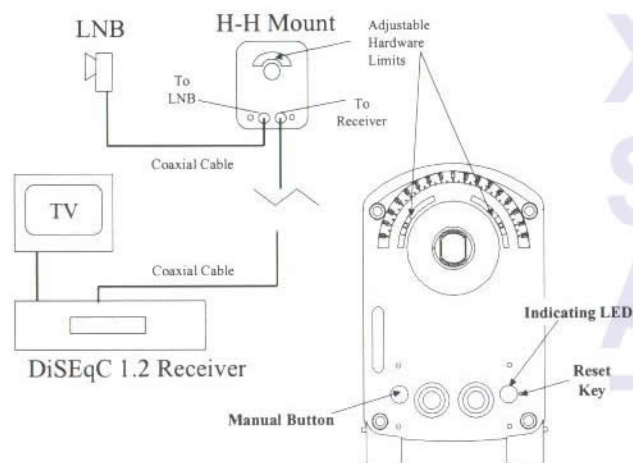

- Please follow the pictures below to protect the F connector with the waterproof rubber sleeve.

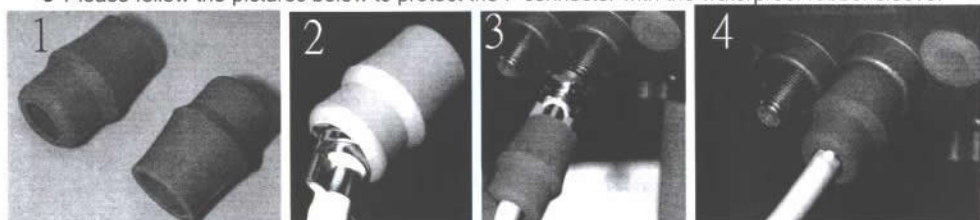

☆ MANUAL BUTTON

Drive the Motor East / West via only one Manual Button on the bottom of the Motor

- West: Press **once** and keep pressing.
- East: Press **twice** within 0.5 second and then keep pressing.
- West Fine-tune: Press **Once** and release immediately for one step West.
- East Fine-tune: Press **Twice** and then release the button for one step East.

☆ INDICATING LED

The LED on the bottom of the Motor can show the following information

Color	Status	Indication
Green	On	Power On; Standby Mode
Orange	Blink	Receiving DiSEqC 1.2 Commands / Reset Mode
Orange	On	Error Message: Over Current / Reach Hardware Limits ...

☆ HARDWARE RESET

- Make sure the power from the receiver is turned on. The indicating LED lights on.
- Drive the motor to 0° via the manual button.
- Probe the RESET button behind the bottom of the motor via a thin rod for 2 seconds. The LED blinks in Orange Color. The reset process is OK while the LED is green. The preset Satellite Table will be re-installed and the current position will be set as 0°. Please cut off the power for the motor first before any operation.

☆ DiSEqC 1.2 OPERATION

The Motor is designed for DiSEqC 1.2 Receiver. The operation on each receiver might be different, but similar. Please refer to the manual of the receiver.

- Go East / West: Drive the dish to East / West.
- Fine Tune East / West: Drive the dish East / West for one step.
- Store nn: Store Satellites Position nn (01-60).
- Goto nn: Drive Motor to Satellite Position nn (01-60).
- East / West Limits: Set software East / West limits.
- Limit Off: Disable the software limits.
- Goto 0°: Drive the Motor to 0° as a reference point.
- Re-synchronize / Shift:
 - Drive the motor to a position by Goto command. For example, **P03**.
 - Drive the motor East / West to a better position.
 - Send Re-synchronize commands to the motor. The **P03** will be shifted to the new position. All the other Satellite positions are also changed.
 - If step a) is skipped, the P01 will be shifted to the new position.

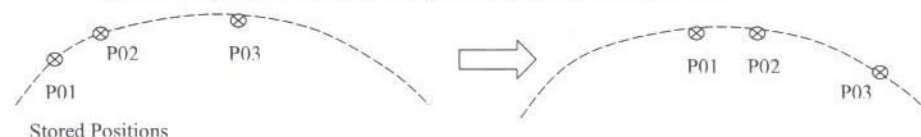

9. Goto X Function:

- This function only works with receivers which have goto x function.
- It can drive the motor to exact $x.x^\circ$ East or West in relative to the 0 position of the motor. (For example, 15.2° East on the bottom of the motor.)
- Just input the longitude, some receivers can drive the antenna to aim the right Satellites automatically

☆ ADJUST THE HARDWARE LIMITS if necessary

The factory preset hardware limits are from 70°East to 70°West. If smaller azimuth range is required, adjust the hardware limits as the following:

1. Always drive the motor to 0 position before adjust the hardware limits.
2. Disassemble the Mounting Tube.
3. Loose the screw on the Limit Slider. Please don't loose the screw thoroughly; otherwise, the Slider might drop into the motor.
4. Adjust the Limit Slider to the wanted angle (20-70°for East or West).
5. Tighten the screws again.
6. Assemble the Mounting Tube onto the motor. Drive the motor East and West via the Manual Button or receiver to make sure the new hardware limits are well set.

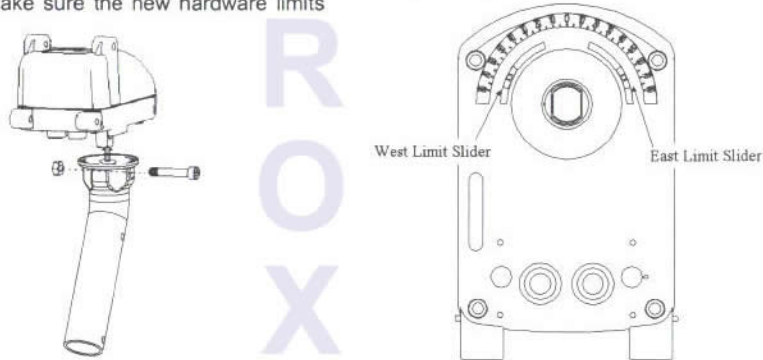

☆ ASSEMBLE THE MOTOR

1. Assemble the H-H Motor as the following diagram.
2. Make sure the mounting pole is exactly **vertical** before installation.
3. Fix the H-H Motor onto the mounting pole.

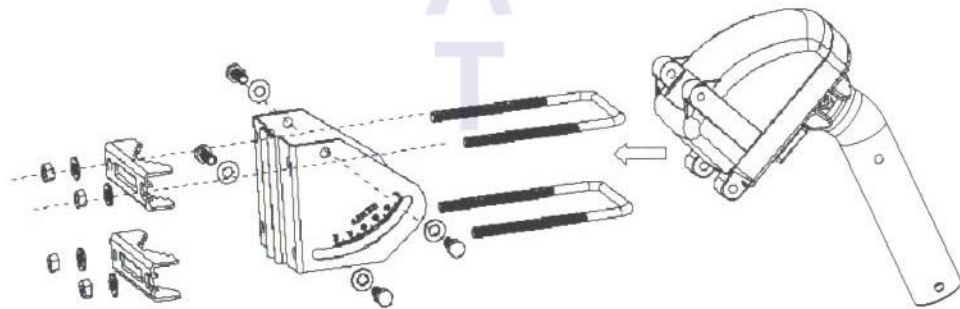

☆ AIMING SATELLITES

I. Traditional Installation:

1. **Aiming TRUE SOUTH.**
Attaching the Antenna Dish to the Motor. Make sure it is at the center of the mounting tube. Rotate the motor together with the antenna toward **TRUE SOUTH**. You can find the TRUE SOUTH via the *magnetic variation table* and a *compass* that indicates the MAGNETIC SOUTH.
2. **Setting Elevation Angle of the Motor. (A)**
According to latitude of your location, set the motor elevation angle via the **Inclinometer** or the Elevation / Latitude scale on both sides of the Motor.
3. **Setting Angle of the Dish. (B)**
 - Attach the Dish onto the motor. The centerline on the tube of the motor can help to mount the Dish on the center. According to the latitude of your location, find the **Declination Angle** by the attached ANGLE TABLE.
 - Set the Declination Angle by the scale on the antenna dish. The reading on the Dish scale should be: **30° - DECLINATION ANGLE**

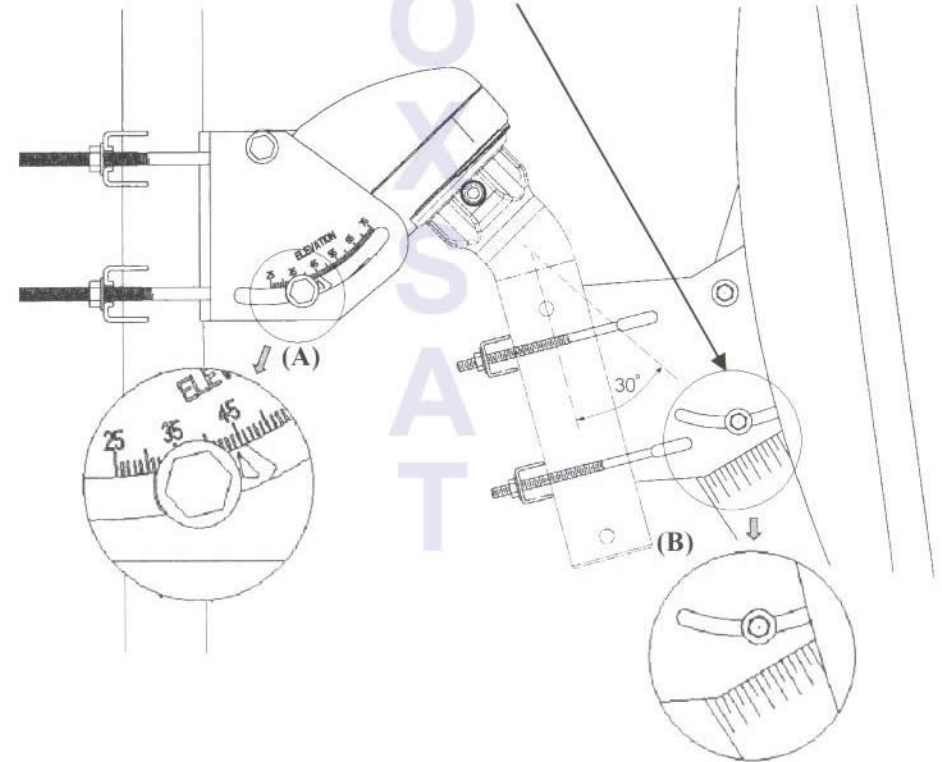

4. Drive the antenna east / west via the manual button on the bottom of the Motor or via Receiver to check if the reception arc is correct. If not, adjust the direction, elevation, and declination angle to find the best reception. Please connect the Motor to the receiver via coaxial cable to get the power. The Green LED will light on if the power from the receiver is on.